

High Performance Differential Elastic Actuator for Robotic Interaction Tasks

Michel Lauria, Marc-Antoine Legault, Marc-André Lavoie, François Michaud

LABORIUS - Research Laboratory on Mobile Robotics and Intelligent Systems
Department of Electrical Engineering and Computer Engineering
Université de Sherbrooke
Sherbrooke, Québec J1K 2R1, CANADA
{Michel.Lauria, Marc-Antoine.Legault, Francois.Michaud}@USherbrooke.ca

Abstract

For complex robotic tasks (manipulation, locomotion, haptics, ...), the lack of knowledge of precise interaction models, the difficulties to precisely measure the task associated physical quantities (force, speed, ...) in real time and the non-collocation of sensors and transducers have negative effects on performance and stability of robots when using simple force or simple movement controllers. To cope with these issues, some researchers proposed a new approach named «interaction control» that refers to regulation of the robot's dynamic behavior at its ports of interaction with the environment. Interaction control involves specifying a dynamic relationship between motion and force, and implementing a control law that attempts to minimize deviation from this relationship [1]. The implementation of machines able to precisely control interaction with its environment begins with the use of actuators specially designed for that purpose. To that effect, a new compact implementation design for high performance actuators that are especially adapted for integration in robotic mechanisms is presented, this design making use of a mechanical differential as central element. Differential coupling between an intrinsically high impedance transducer and an intrinsically low impedance spring element provides the same benefits as serial coupling [4]. However differential coupling allows new interesting design implementations possibilities, especially for rotational actuators.

Introduction

The popular representation of robotic systems depicts robots as cold and stiff articulated machines. This is due to the fact that the major part of the robots that are used in the industry are in fact designed and optimized to be fast and precise manipulators acting in constrained environments for “pick and place” tasks. Speed controlled joints and stiff transmission mechanisms are the fundamental building blocks of these machines. These robots are faster, more precise and stronger than human beings. However, they can execute only one specific category of task in a strictly constrained and controlled environment. Building more versatile robots is possible by putting a force sensor in the end effector and by using a hybrid position/force

controller. However, the performance of manipulation tasks that can be executed is limited to assembly of very simple mechanical parts (“peg in hole” task).

New trends in Robotic Actuation Technology: High Performance Variable Impedance Actuators for Robotic Interaction Tasks where power exchange with environment is not negligible

Implementation of machines able to precisely control interaction with the environment begins with the use of actuators specially designed for that purpose. This is a new research trend. The few publications that can be found on that subject show that this new category of high performance actuators is difficult to implement, particularly within compact volumes and large force/power outputs. Since fifteen years, several researchers proposed different implementations:

- **Impedance Controllable Direct Drive Actuators:** These actuators use a low intrinsic impedance transducer+transmission mechanism, collocated sensors and fast analog impedance control algorithms to close the loop. Variable impedance is obtained by changing the parameters of the controller [2,3].
- **Series Dynamic Actuators:** These actuators use low impedance compliant and/or viscous elements in series between a high impedance transducer+transmission mechanism and the load. Non-collocation of the sensors and transducer limits their utilization for precise and fast force control tasks [4].
- **Variable Stiffness Actuators:** Variable stiffness actuators use a variable stiffness transmission mechanism. All the proposed implementations make use of two non-linear mechanical springs working in antagonistic configuration (like muscles). One additional transducer allows changing the mechanical impedance of the actuator during motion [5].

- **Parallel Coupled Micro-Macro Actuators:** These actuators use a high power series elastic actuator in parallel with a low power direct drive transducer. The serial elastic actuator contributes for «low frequencies/high amplitude» forces while the direct drive actuator contributes for «high frequencies/low power» forces [6].

If we look specifically at rotational actuators, none of these proposed implementations is adapted for compact product integration and mass production apart the «Impedance Controllable Direct Drive Actuator». In particular, the proposed rotational «series dynamic actuators» suffer from several implementation drawbacks due to the serialization of an intrinsically low impedance mechanical component with the intrinsically high impedance motor.

Theoretical background

Mechanical impedance can be associated to any mechanism having one degree of freedom. This complex variable determines the dynamic properties of the mechanism from the interface point of view. It can be seen as the transfer function of the black box model of the system:

$$Z(j\omega) = \frac{Force(j\omega)}{Speed(j\omega)} \quad (1)$$

Stationary linear systems can be modeled with impedance diagrams. Electrical impedance diagrams are abundantly used to analyze electrical circuits in steady state operation (figure 1). In this paper, the force/tension analogy will be used to depict models of differential actuators. To be able to understand the mechanical impedance diagrams, the following information has to be kept in mind:

- A force/torque can be associated with a voltage;
- A speed can be associated with a current;
- An ideal source of force can be associated with an ideal source of voltage;
- An ideal source of speed can be associated with an ideal source of current;
- A mass can be associated with an inductor;
- A spring can be associated with a capacitor;

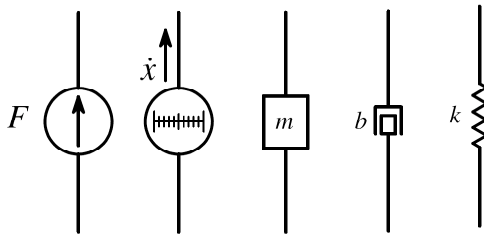

Fig. 1 — List of symbols used in the mechanical impedance diagrams, from left to right: an ideal source of force, an ideal source of speed, a mass, a viscous damper, a spring.

- A viscous damper can be associated with a resistor.
- An ideal speed reducer (gearbox) can be associated with an ideal electric transformer.

A mechanical differential is a mechanism that provides a coupling between three mechanical ports. Basically, any «two ports» mechanism that provides force/torque amplification by a factor K can be used in a «three ports» differential configuration mode. The kinematical relationship between the three rotational/linear speeds is given by the Willis equation:

$$\dot{x}_1 + K \cdot \dot{x}_2 = (1 + K) \cdot \dot{x}_3 \quad (2)$$

The kinetic relationships between the three force/torques are given by the following equations:

$$\begin{cases} F_2 = K \cdot F_1 \\ F_3 = (K + 1) \cdot F_1 \end{cases} \quad (3)$$

It can be described with an equivalent mechanical impedance diagram using two ideal speed reducers.

The differential actuation concept

In this section, we will demonstrate how a mechanical differential can be used as central element of coupling between two transducers T1 and T2 to create compact high performance actuators adapted for robotic interaction tasks (figure 2). The physical implementation of the mechanical differential does not change the working principle of the differential actuation concept. Possible implementations of a mechanical differential include the utilization of a standard gearbox, the utilization of a harmonic drive, the utilization of a cycloidal gearbox, the utilization of a bar mechanism, the utilization of a cable mechanism and all other mechanism that implement a differential function between three mechanical ports. Transducer T2 is a controllable source of speed. High intrinsic mechanical impedance of T2 is suitable but not absolutely necessary. When designing a high performance differential actuator, the following expression has to be respected:

$$(K + 1)^2 Z_2 \gg Z_1 \quad (4)$$

The mechanical differential will act as a speed reducer for T2 from the load point of view. Thus, if the intrinsic mechanical impedance of T2 is low, the gear ratio and the intrinsic friction of the differential will contribute to

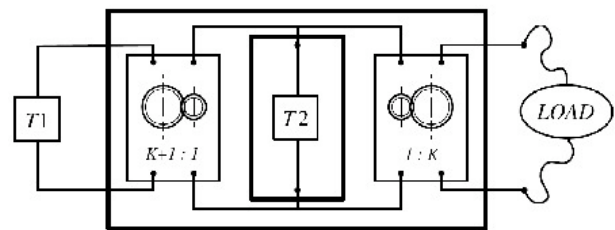

Fig. 2 — The differential actuation concept impedance diagram.

increase the equivalent impedance of T2 seen from the load. It is not necessary to have a precise control on the exact value of the mechanical impedance of T2, as it does not affect the working principle of the differential actuation concept. T2 can be implemented using a direct drive electromechanical transducer connected to a high gear ratio differential and with a feedback speed controller. Depending of the nature of transducer T1, several categories of high performance differential actuators can be distinguished. In this paper, we will concentrate on the utilization of a passive mechanical spring to implement T1. Let's compute the total equivalent mechanical impedance Z_{eq} seen from the load point of view. To understand the calculation, one should remember that a differential acts like two electrical transformers and that the two equivalent mechanical impedances Z_1 and Z_2 of T1 and T2, respectively, are connected in parallel in the impedance diagram.

$$Z_{eq} = Z_1 \frac{K^2}{(K+1)^2} // Z_2 K^2 = \frac{Z_1 Z_2 K^2}{(K+1)^2 Z_2 + Z_1} \quad (5)$$

Using equation 4, the expression of Z_{eq} can be approximated by:

$$Z_{eq} \approx \frac{K^2}{(K+1)^2} \cdot Z_1 \quad (6)$$

The fundamental property of the differential actuation concept is that there is a precise known relationship between the mechanical impedance of the actuator and the mechanical impedance of T1. The mechanical impedance of T2, which is in general very difficult to model, does not influence the mechanical impedance of the actuator. That means that interaction control between the actuator and the load can be performed uniquely with impedance and/or force control of T1.

Differential coupling of two transducers is quasi equivalent to serial coupling when computing the impedance seen from the load. Differential coupling may offer

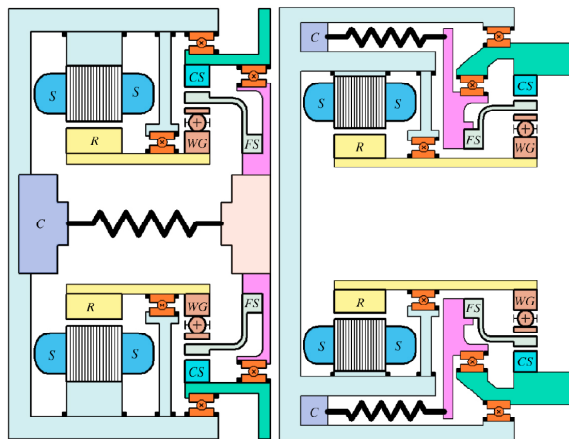

Fig. 3 — Two possible designs of rotational differential elastic actuator using a hollow shaft harmonic drive.

implementation advantages compared with serial coupling. In particular, high performance rotational actuators are best implemented using a differential coupling between transducers T1 and T2 than using a serial coupling. The advantages are:

- A more compact design.
- A more simple design. T1 is a limited angle transducer connected to a fixed point. That means that there is no need of slip rings.

Implementation of a rotational differential elastic actuator

Utilization of the harmonic drive technology to implement the differential mechanical function of rotational differential actuators provides a very compact and simple design. The three building components (wave generator WG, flexible spline FS, circular spline CS) of harmonic drive systems can be bought separately. Their hollow shaft systems allow several different possible implementations for rotational differential actuators. In these designs, T1 is a torsion spring, with a known impedance characteristic. T2 is a rotational direct drive brushless motor. A non-turning sensor (C) measures the torque output of the actuator. Figure 3 shows three possible designs of rotational differential actuators using a hollow shaft harmonic drive.

References

- [1] Hogan, N., Buerger, S. P. (2005), «Impedance and Interaction Control», *Robotics and Automation Handbook*, CRC Press, pp. 19.1-19.24.
- [2] Fasse, E. D., Hogan, N., Gomez, S. R., Mehta, N. R. (1994), «A novel Variable Mechanical Impedance Electromechanical Actuator», *Dynamic Systems and Control*, DSC Vol. 55-1, Volume 1, pp. 311-318.
- [3] Aghili, F., Buehler, M., Hollerbach, J. M., «Development of a High Performance Direct-Drive Joint», *Journal of Advanced Robotics*, 16(3):233-250, 2002.
- [4] Robinson, D. (2000), «Design and Analysis of Series Elasticity in Closed Loop Actuator Force Control», PhD Dissertation, Massachusetts Institute of Technology, Cambridge, Boston.
- [5] Bicchi, A., Tonietti, G., Bavaro, M., Piccigallo, M., «Variable Stiffness Actuators for Fast and Safe Motion Control», in B. Siciliano, O. Khatib, and F.C.A. Groen, editors, *Proceedings of ISRR 2003*, Springer Tracts in Advanced Robotics (STAR). Springer Verlag, 2003.
- [6] Zinn, M., Khatib, O., Roth, B., Salisbury, J. K., «Playing it safe : human-friendly robots», *Robotics & Automation Magazine*, IEEE Volume 11, Issue 2, June 2004, pp. 12 – 21.